

0.828	0.879
1.138	1.428
2.073	2.363
2.622	2.679
2.938	3.228
3.873	4.163
4.422	4.473

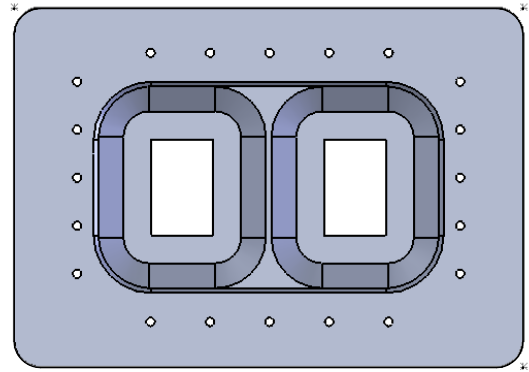

R0.276
4 PLACES
R0.267
8 PLACES

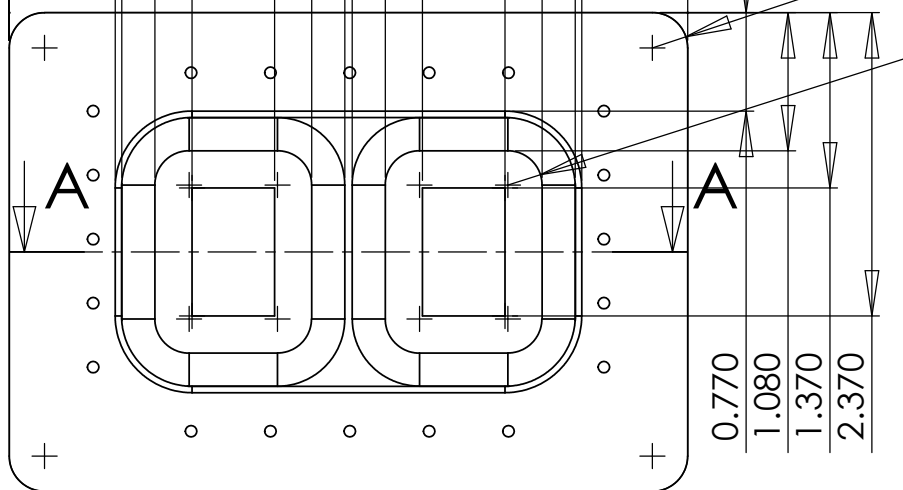

0.770
1.080
1.370
2.370

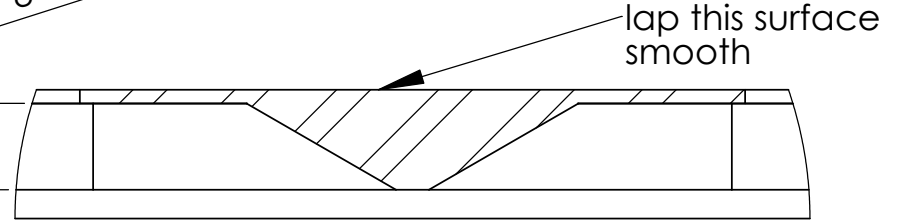

DETAIL D
SCALE 3 : 1

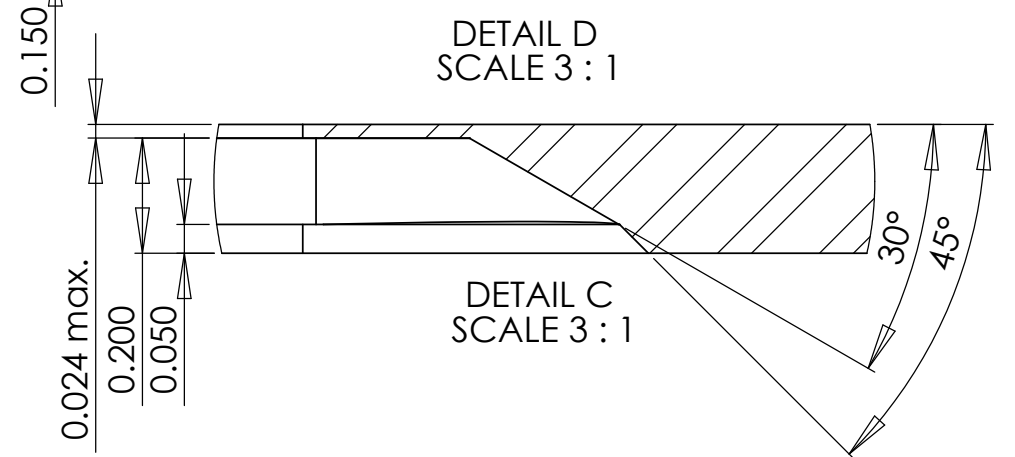

DETAIL C
SCALE 3 : 1



SECTION A-A
SCALE 1 : 1.5

PROPRIETARY AND CONFIDENTIAL
THE INFORMATION CONTAINED IN THIS DRAWING IS THE SOLE PROPERTY OF Church Lab, Harvard Medical School. ANY REPRODUCTION IN PART OR AS A WHOLE WITHOUT THE WRITTEN PERMISSION IS PROHIBITED.

		UNLESS OTHERWISE SPECIFIED:	NAME	DATE
		DIMENSIONS ARE IN INCHES	DRAWN	GJP 08-09-2006
		TOLERANCES:	CHECKED	
		FRACTIONAL ±	ENG APPR.	
		ANGULAR: MACH ± BEND ±	MFG APPR.	
		TWO PLACE DECIMAL ±	Q.A.	
		THREE PLACE DECIMAL ±	COMMENTS:	
		INTERPRET GEOMETRIC TOLERANCING PER:	we hand-lap surface w/ 200, 400, then 600 grit wet sandpaper on a glass plate	
		MATERIAL	410 stainless	
		FINISH		
NEXT ASSY	USED ON			
APPLICATION		DO NOT SCALE DRAWING		

TITLE:		
Harvard flowcell V3 bottom plate 1		
SIZE A	DWG. NO. bottom_plate_part1	REV
SCALE: 1:2	WEIGHT:	SHEET 1 OF 1